

HARBOUR MASTERS REPORT 4th September 2024
Part 1

PMSC

Standing position until report is available.

On the 21/3/2023 I am pleased to report that The MCA undertook a Port Marine Safety Code Health Check. We are still awaiting the report. I have sent request to the MCA for a potential delivery date. I have had confirmation that this report should be available in time for our next meeting.

Further to my last, there still has not been a report produced. I will continue to pressure.

NAVIGATION

Work has proceeded well on the fabrication of the Mussel Bank perch. We now aim to complete early September.

Operational Stages

- Etch priming and the application of the topcoat to the perch section and top mark.
- The installation and fixing down of the receiving base. (Steel)
- The positioning of the first concrete ring and the casting of concrete. Up to 75% of the available volume.
- The installation of the second ring and the casting of the remaining concrete.
- The installation of the perch mast.
- The installation of the stainless stays.
- The fitting of the top mark and light.

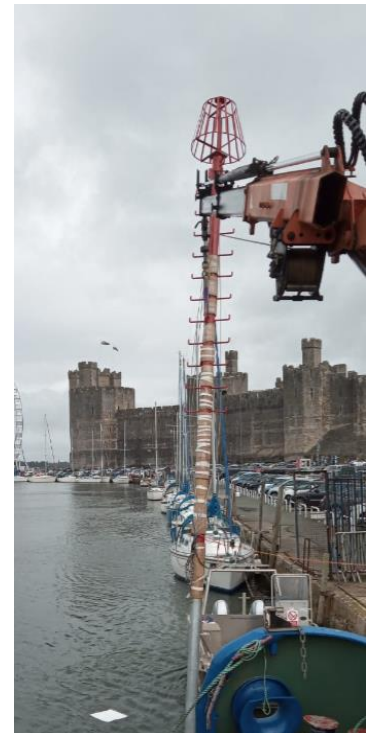

HARBOUR MASTERS REPORT 4th September 2024

Part 1

A new design AtoN base has been manufactured that will allow the top mark to be changed out for the required top mark. This design will be the sole design moving forward. This is effectively the original design modified to allow differing top marks to provide greater flexibility in our system.

Original Design

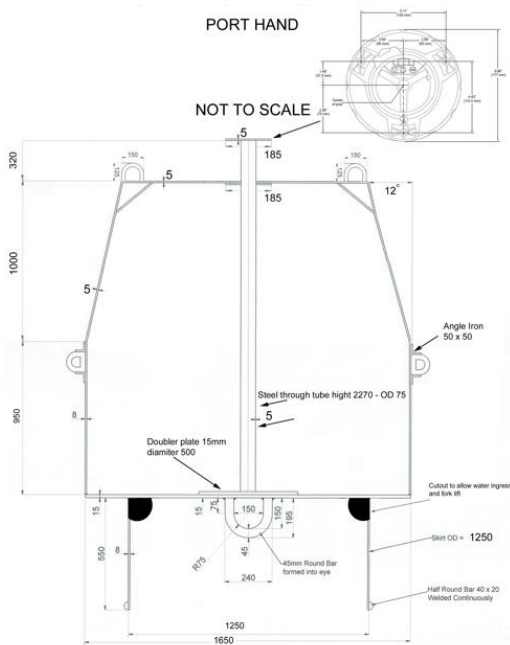

Modified Design

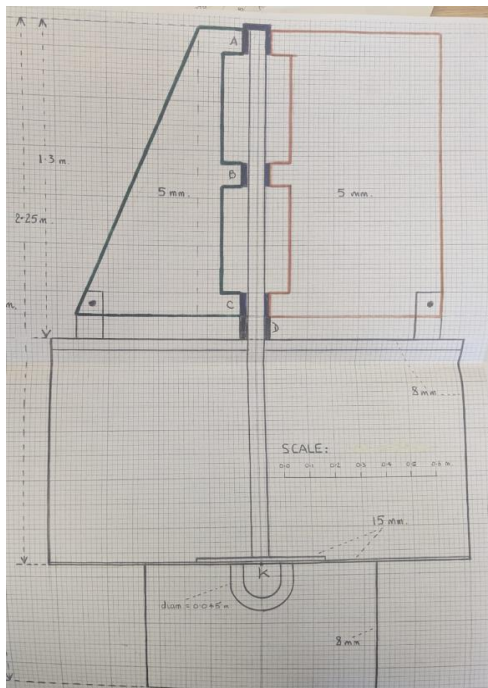
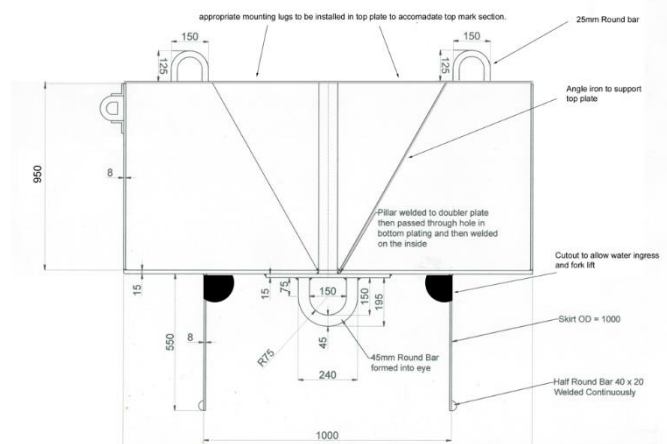

HARBOUR MASTERS REPORT 4th September 2024
Part 1

NtoMs

- 01-24 Perch Indefatigable
- 02-24 Cancel NtoM 15-21
- 03-24 Perch Indefatigable
- 04-24 C5 Off Station
- 05-24 C5 On Station
- 06-24 C1 On Station
- 07-24 C3 On Station
- 08-24 C2 On Station
- 09-24 C4 On Station
- 10-24 C2 Unlit
- 11-24 C1 Off Station
- 12-24 C1 On Station
- 13-24 C2 Lit
- 14-24 SWM On Station
- 15-24 Grampian Castle On Station
- 16-24 Aber Bridge, Gwyl Fwyd
- 17-24 Grampian Castle Unlit
- 18-24 Grampian Castle Off Station
- 19-24 Grampian Castle On Station
- 20-24 Special markers MB Construction
- 21-24 MB Construction
- 22-24 OCRDA
- 23-24 Aber Bridge



YEAR	NOTICE TO MARINERS ISSUED
2014	15
2015	13
2016	9
2017	28
2018	16
2019	29
2020	21
2021	38
2022	21
2023	20
2024	23

On the 13/8/24 Trinity House undertook their annual audit Inspection of our Local Aids to Navigation, under the Merchant Shipping Act, 1995, Section 198, this was a desktop audit inspection to ensure our record keeping is in order. Full findings in correspondence.

HARBOUR MASTERS REPORT 4th September 2024

Part 1

Pilotage

No acts of pilotage to report.

Seiont IV

On the 19/08/24 the Seiont undertook its 17th annual Survey, the vessel was found to be in good order., with minor issues requiring to be resolved. Primarily due to having been repainted. Draft Markers needing to be painted white and an Inclinator needed replacing.

The vessel is afloat and ready for service.

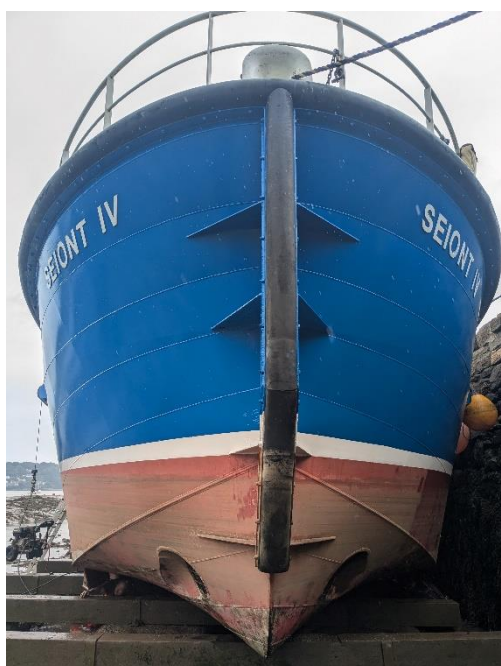

Y Foryd

The vessel is afloat and ready for service.